



USTER® *TENSOJET 5*

The WEAVABILITY™ measurement system

Technical Data

February 2020

USTER® TENSOJET 5

The WEAVABILITY™ measurement system

High performance tensile instrument gives a precise forecast of yarn runability for high performance processes with a testing speed of 400 m/min.

Elements of the USTER® TENSOJET 5 installation

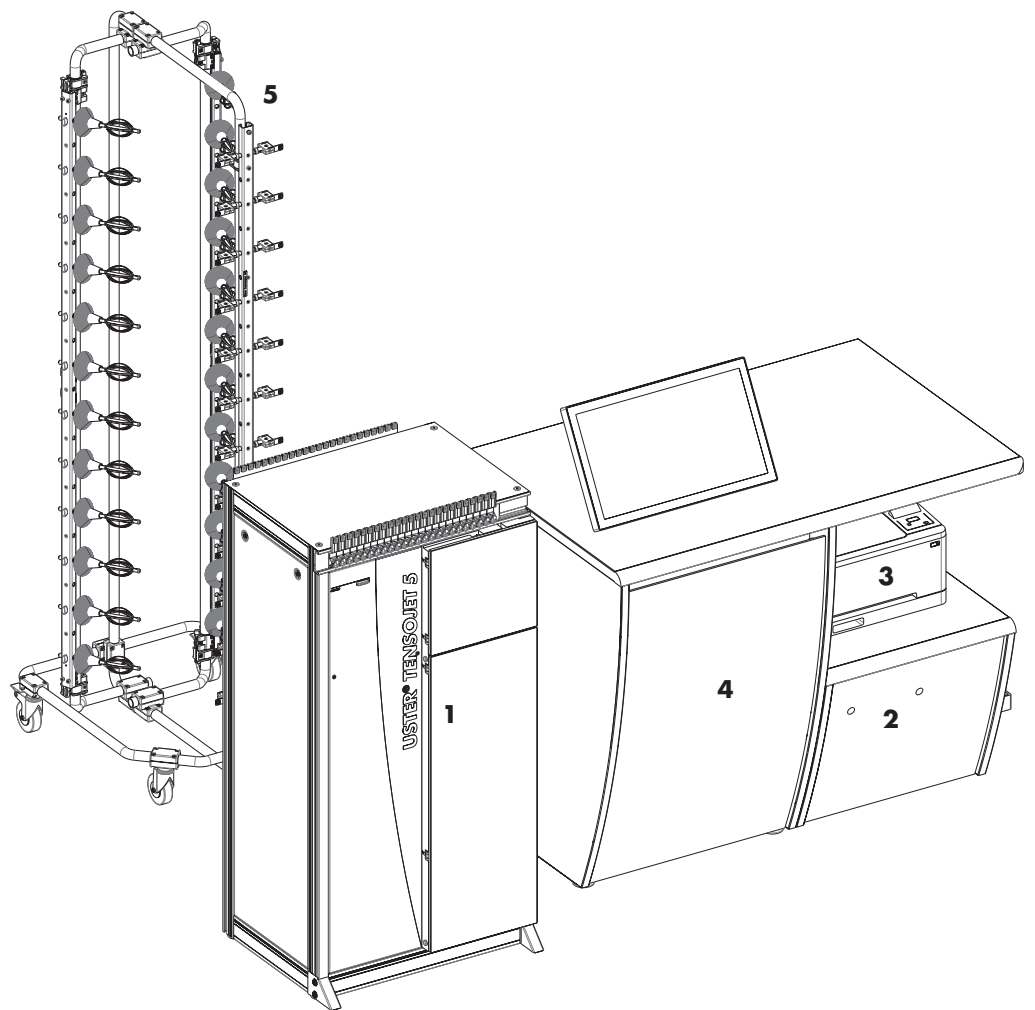

Basic installation

- 1 Test unit
 - Sensor for force and elongation
 - Sensor temperature and humidity
- 2 Control unit
- 3 Printer
- 4 Table with touchscreen and integrated waste box

Options

- 5 Package truck
- 6 Calibration device ISOINSPECT (no illustration)

USTER® TENSOJET 5

The WEAVABILITY™ measurement system

Basic installation

Overall Installation	Functions	<ul style="list-style-type: none"> – Measurement of tensile strength and elongation of staple fiber yarns – Analysis, evaluation and storage of measurement values – Automatic check of all measured values – Yarn classification based on the USTER® STATISTICS – Editor for customizing reports and setting of mill limits – Filter functions for quick data selection and for the preparation of long-term reports
	Included in the delivery	<ul style="list-style-type: none"> – Test unit – Control unit – Touchscreen – Printer – Application software – Table

Subsystem of the USTER® TENSOJET 5 basic version:

Test unit (1)	General instrument type	<ul style="list-style-type: none"> – Recommended for staple fiber yarns 5 – 150 tex (Nm 7 to 200; Nec 4 to 119) – Special staple fiber yarns on request: especially for linen yarns, plied yarns, waxed yarns, technical yarns, silk yarns, slub or fancy yarns, high-volume yarns – It is not recommended to measure core yarns
	Measuring principle	Constant rate of extension CRE
	Testing method	Simple tensile test. Testing capacity 30 000 per hour at 400 m/min testing speed
	Force measuring arrangement	Practically inertialess electronic force measurement
	Elongation measuring arrangement	<ul style="list-style-type: none"> – Electronic elongation measurement – Measuring accuracy for force and elongation measurement: for force $\pm 1\%$ (above 100 cN) or ± 1 cN (below 100 cN), and for elongation $\pm 1\%$
	Clamp speed	200 and 400 m/min
	Pre-tension	Adjustable between 5 and 500 cN

USTER® *TENSOJET 5*

The WEAVABILITY™ measurement system

	Test lengths	500 mm (necessary yarn length 800 mm/break)
	Force measuring range	0.7–30 N
	Elongation measuring range	3–30 %
	Yarn changer	<ul style="list-style-type: none">– Automatic selection of the yarn from the sample into the measuring zone– Setup of 24 samples, finishing of the incomplete test after end of the test
Control unit (2)	Computer software	<ul style="list-style-type: none">– USTER® <i>TENSOJET 5</i> intuitive touch application software– Windows Embedded 8.1 operating system– System pre-configured and locked down– Simple full system update process
	Computer hardware	<ul style="list-style-type: none">– Industrial computer with Intel processor– 3 internal hard drives for data security and system redundancy– 1 TB test data storage
	Computer accessories	<ul style="list-style-type: none">– Large easy to read touchscreen monitor– Laser printer

USTER® TENSOJET 5

The WEAVABILITY™ measurement system

Application software

Reports	Type of report	<ul style="list-style-type: none"> – Standard test report of the measurement series – USTER® Quality Report (summary of the key data and the test results on one page; quality certificate) – Pre-defined table reports and graphical reports for different application – Long-term reports
	Display and printout of the reports	<ul style="list-style-type: none"> – Live view report during the measurement – Analysis tool with all measured data and graphical output – Smart view report for exceptions and outliers – Automatic printout possibility after the measurement
	Limit values	<ul style="list-style-type: none"> – Setting of customized limits according to the USTER® STATISTICS, standard deviation, relative and absolute count – Automatic verification of the measured value – Measured values which exceed the limit will be marked with red or purple color in the report
Numerical results	Breaking force	Maximum force value measured during the tensile test
	Breaking elongation	Elongation at maximum breaking force value
	Tenacity	Breaking force in relation to the yarn count of the sample
	Breaking work	Work done to break (enclosed area below the force/elongation characteristic curve up to the point of breaking force)
Statistics	Statistical values	<ul style="list-style-type: none"> – Mean value – Standard deviation s – Coefficient of variation CV – Q95 % confidence interval – Minimum value – Maximum value – Percentage values – 0.01 / 0.05 / 0.1 / 0.5 and 1 % of the total breaks are smaller or equal to the indicated force, elongation and work – Number of isolated weak places – USP™ (USTER® STATISTICS Percentile) – UTRexp (expected traditional tensile value USTER® TENSORAPID, testing speed: 5 m/min, test length: 500 mm)
	USTER® STATISTICS	<ul style="list-style-type: none"> – Comparison of measured values with the USTER® STATISTICS – Material-dependent USTER® STATISTICS are stored in the data-base – Setting of limit values based on the USTER® STATISTICS

USTER® TENSOJET 5

The WEAVABILITY™ measurement system

Graphic output of results

Stroke diagram

Available for breaking force and elongation

Histogram

Available for force and elongation

Force/elongation scatter plot

- Show all single measurements as individual points in scatter plot
- Easier detection of the sample due to different colors

Spectrogram

- Available for force and elongation
- Pre-condition: needs 200 within tests per sample

Data protection

Backup

Automatic backup to dedicated internal hard drive every 15 minutes

Input of data, output of results, languages, units

Dialog and report languages

English, German, French, Italian, Spanish, Portuguese, Turkish, Russian, Chinese or Japanese can be selected (other languages on request)

Possible units

- Force values:
DN, N, cN, kgf, gf, lbf, ozf
- Yarn count:
ktex, tex, dtex, denier, Nm, Nec, Nel, New, grn/yd, Y.S.W.
- Tenacity:
mN/tex, cN/tex, gf/denier, Rkm, CSP, MPA

System security

Protection function

- System protected from viruses, network and other security threats
- Remote support capabilities built in
- Diagnostic tools with extensive event logging
- Automated system recovery

USTER® TENSOJET 5

The WEAVABILITY™ measurement system

General

General ambient conditions	Room climate	<p>The ambient conditions must be maintained in order to avoid any influencing of the test material according to ISO 139 (2015)</p> <ul style="list-style-type: none"> – Humidity: 65±4 % – Temperature: 20±2 °
Installation data	Electrical connection	Single-phase mains with protective conductor
	Mains voltage range	100 – 240 VAC
	Mains frequency	50/60 Hz
	Power consumption	Maximum 1000 VA (all units and motors switched on)
	Compressed air consumption	40 m ³ /h with normal pressure (atmospheric pressure)
	Compressed air connection	<ul style="list-style-type: none"> – Air quality: according to ISO 8573.1, class 3 – Min. pressure at inlet of air filter regulator: 6 bar – Max. pressure at inlet of air filter regulator: 10 bar
	Dew point	2 to 3° C or lower at atmospheric pressure
	Oil content	Oil-free, or residual oil content <1 mg/m ³
	Solids content	<5 mg/m ³ , particle size <5 mm
	Noise level of the suction nozzle	Maximum 70 dB(A) at 1 m distance, depending on the yarn, count noise can be lower
Weight of the installation	Tester	153 kg
	Table with waste yarn container	103 kg
	Complete system	290 kg

USTER® TENSOJET 5

The WEAVABILITY™ measurement system

Uninterrupted power supply (UPS)

UPS must be provided by the customer

	UPS Model	Tower
	UPS Bypass Type	ON-Line
Electrical Input	Nominal Voltage	120 VAC, 220–240 VAC
	Voltage range 120 VAC	90–138 VAC
	Voltage range 230 VAC	160–276 VAC
	Frequency	50/60 Hz
Output	Nominal Output Voltage	120 VAC, 230 VAC
	Power Capacity	1 500 VA (1.5 kVA)/1 350 W
	Voltage regulation	+/-3 %
Environment	Safety markings 120/208 V	UL, CUL, VCCI
	Safety markings 230 V	CE, GS
	Ambient operating temp.	Laboratory condition are acceptable
	Relative humidity	Laboratory condition are acceptable

Note: It is not permitted to connect a Laser Printer.

USTER® TENSOJET 5

The WEAVABILITY™ measurement system

Space required for the
USTER® TENSOJET 5

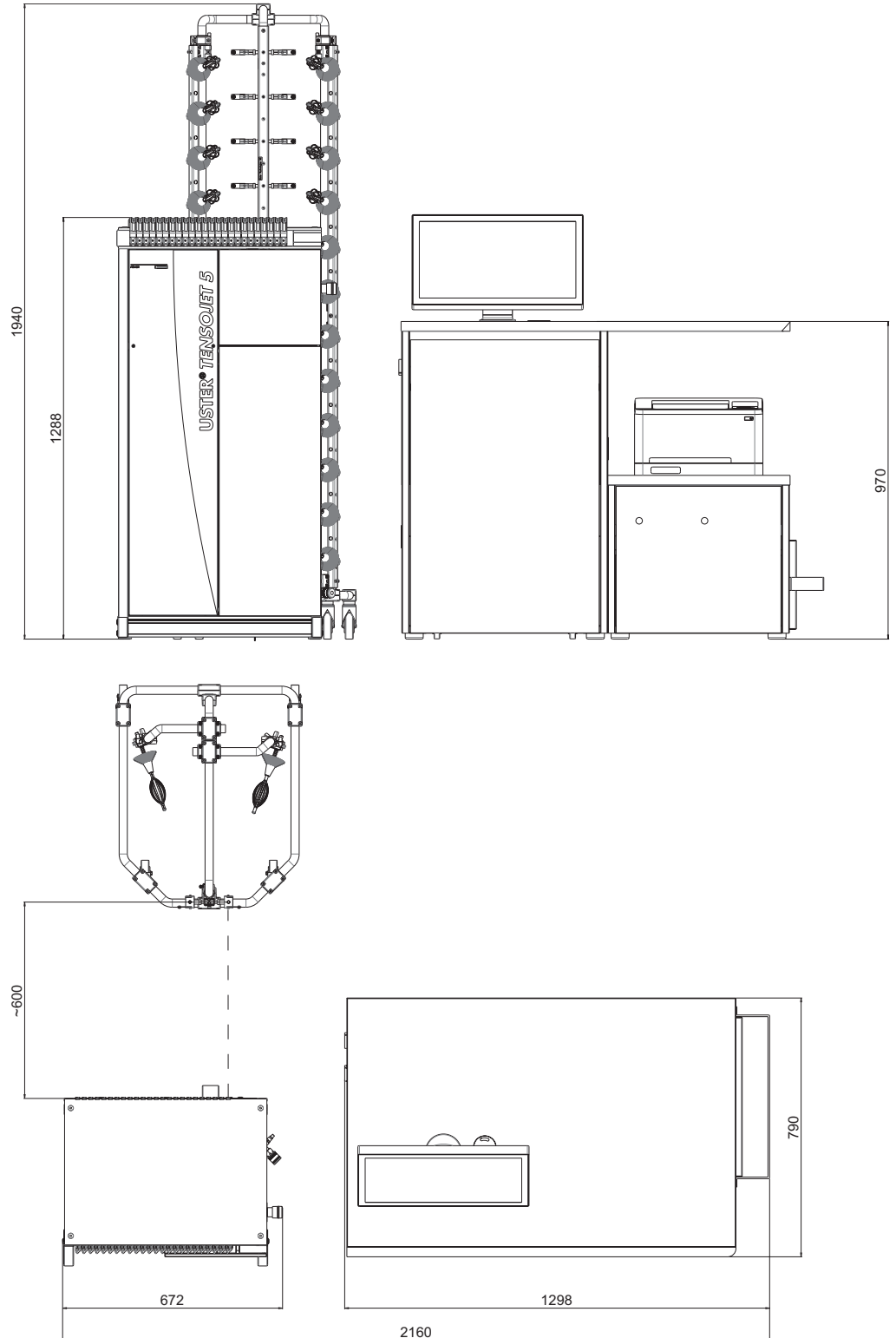

Uster Technologies has made all possible efforts to ensure that all information is accurate at the time of publication. Hereby it is declared that alterations to the product may be possible at any time. In these cases the information contained in this technical datasheet is subject to change without notice.

February 2020



Uster Technologies AG

Sonnenbergstrasse 10

8610 Uster

Switzerland

T. +41 43 366 36 36

F. +41 43 366 36 37

sales@uster.com

www.uster.com